

**FRE**  
COMPOSITES®

**FIRST IN THE FIELD**

# TABLE OF CONTENTS

- **Company's history**
- **Product Lines review**
  - **THE EPOXIES**
  - **THE PHENOLICS**
- **Targeted Market segments**
  - Utilities (Power & Fiber)
  - C&I (Power)
  - Transit (Power & Fiber)
- **Questions & Answers**



## FROM 1958 TO TODAY

LongSault Woodcraft - DEW Lines (Distant Early Warning System - NORAD)

General Electric Canada 1966 - Fiber Reinforced Engineered Products division

Fiberglass conduit development - RTRC (own publication)

**FRE®** Registered Trademark in 1970 both in the United States and Canada

**1978** Fact Finding investigation at Underwriters Laboratories

1 - CIBA Geigy

2 - General Electric Canada

**1984** Publication of 1<sup>st</sup> Fiberglass conduit standard (NEMA TC14)

**1988** GE sells to a Management Buyout - FRE Composites is incorporated

**1992** FRE Composites is acquired by Héroux Inc., Canadian Aerospace major

**1993** CSA introduces Type AG - for above grade non-hazardous locations

**1993** BreathSaver® conduit is introduced into the market (own publication)

**1996** UL/CSA Harmonized Standards (UL1684)

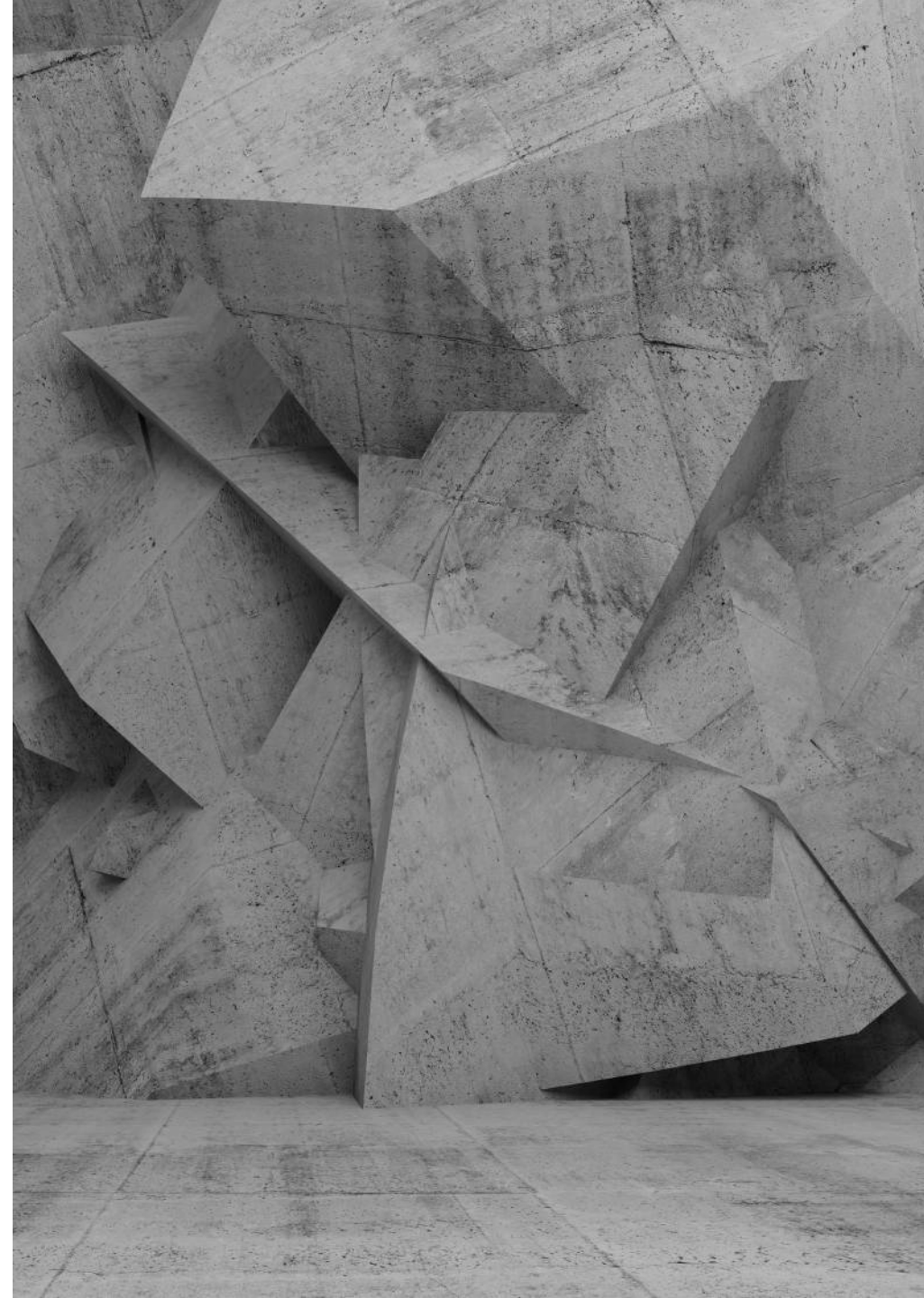

## FROM 1958 TO TODAY

- 1998** Exiting the aerospace market- SSRMS completed & delivered
- 1999** Héroux sells FRE Composites to investors group (lead by myself)
- 2000** BreathSaver® - Registered trademark both in the USA and Canada
- 2005** FRE Composites restructuring
- 2007** FRE Composites is 100% owned by Benoit Arsenault
- 2008** HazGuard™ conduit- NEC recognized for Class 1 Division 2 locations- Subjected to physical damage locations
- 2012** XW Breathsaver® is tested at UL Northbrook IL against UL 2196
- 2012** Later in the year; UL rescinded all FHIT - Certification for 2-Hour Fire rating systems (cable or cable in conduit - all material types)
- 2015** UL publishes FHIT 25C - The only 2-Hour Fire Certified system both for Horizontal and Vertical installations in the United States
- 2019** Alexandre Arsenault, Executive VP of FRE Composites Group joins in as a significant minority shareholder of the Group



The image is a composite of two grayscale photographs. The left half shows an aerial view of a city with a dense urban core and a highway interchange in the foreground. The right half shows a close-up, low-angle view of server racks in a data center, with numerous cables and metal frames visible.

THE EPOXIES

---

**FRE<sup>®</sup>** Type BG and Type AG

UL 2420 – UL 2515

## **FRE®** Conduit system design & Characteristics (Own publications from 1970 to 1984)

- Compressive strength
- Impact strength
- Coefficient of friction
- Temperature rating (-40° F to 230° F)
- Heat transfer ability (higher voltage)
- Thermal stability (0.015" per ° F over 100 feet)
- Watertight system (**TriSeal™**)
- Chemical resistance (epoxy)
- Resistance to cable fusion when shorted
- Weight
- Handle ability
- Water absorption
- Flame resistance (*same testing requirements as PVC-UL 651*)
- Flexibility
- Storage stability
- Installed cost per foot – **Triseal™** push-fit assembly
- Complete range of fittings & accessories

## **FRE®** Conduit Listing & Certification Type BG & AG

### **UL Listing**

The National Electrical Code in Article 355 recognizes “Reinforced Thermosetting Resin Conduit (RTRC)” as an acceptable conduit material. “**FRE® Conduits**” is Listed by Underwriters Laboratories Inc. under file number E53373.

Compliance to NEMA TC14 A & B Standards (Oct. 18th, 2002 - Adoption of UL standards).

### **CSA Certification**

**FRE® Composites' Above Ground Conduit** system is recognized by the Canadian Electrical Code in Articles 12-2500 to 12-2512 as an approved conduit material.

The product is CSA certified by the electrical division per the requirements of Bulletin 1089A under the certification number LL28032. The product also carries CSA mechanical division certification under listing number LM32667 per the requirements of Bulletin B196.1.



## **FRE®** Conduit – Product characteristics

- **Lightweight:** 100 feet of 4" weighs 70lbs
- **Compressive strength:** Axial 12,000 Psi ASTM D695
- **Tensile strength longitudinal:** 7,000 Psi per ASTM D638
- **Ultimate elongation:** 2% per ASTM D2105
- **Modulus of elasticity intension:** 1,250,000 per ASTM D2105
- **Modulus of elasticity in bending:** 1,250,000 per ASTM D790
- **Thermal conductivity:** 2.0 BTU / HR / SQ / F° / Inch
- **Coefficient of linear thermal expansion:** 1.25 x 10.5 " / inch / °F
- **Specific gravity:** 1.94
- **Temperature range:** -40°F to 230°F
- **Dielectric strength:** 500 volts / per mil
- **Dissipation factor:** 0.5% average at room temperature per ASTM D348
- **Barcol hardness:** 52 per ASTM D2583
- **Glass content:** 68% per API 15LR
- **Water absorption:** <1% per ASTM D570
- **Flammability:** HB rating UL 94 / Article 5.10 (UL 2515)
- **Heat deflection temperature (HDT):** 312°F (156°C) ASTM D648
- **Integral urethane gasket (TriSeal™)**



## FRE® Conduit – Physical Properties (Standard Wall Conduits)

**Specific Gravity:** 1.94 ASTM D 792  
**Barcol Hardness:** 52 ASTM D 2583  
**Glass Content:** 68% +/-3 API Spec.15LR

SIZE	LENGTH	WEIGHT		WALL THICKNESS
		lbs/length	lbs/foot	
2"	19'-10"	7.2	0.36	.070"
3"	19'-10"	11.6	0.58	.070"
4"	19'-10"	14.4	0.73	.070"
5"	19'-10"	24.0	1.21	.095"
6"	19'-10"	29.5	1.49	.095" (6ID) / .110"(6IPS)

An aerial, grayscale photograph of a city, likely Atlanta, Georgia, showing a dense urban landscape with numerous skyscrapers and a complex, multi-level highway interchange in the foreground. The image is used as a background for a technical advertisement.

THE EPOXIES

**FRE**<sup>®</sup> Conduit for Bridge Installations

Type AG UL 2515

### Weight of **FRE®** Conduit— Type AG

- Considerable savings in conduit hangers and supports can be realized due to **FRE®**'s light weight and high flexural strength.
- **FRE®** Conduit is twice the strength to weight ratio than PVC and much lighter weight than steel and aluminum alternative products.
- Complete tables of weights and measures are provided in the Above Ground Conduit catalog.

### Thermal Expansion of **FRE®** Conduit— Type AG

- Thermal expansion is a major advantage for bridge applications.
- **FRE®**'s low thermal expansion is on 40% of that of P.V.C. conduits hence reducing the number of expansion joints required.
- **FRE®**'s coefficient of thermal expansion is a low  $1.37 \times 10^{-2}$  in/in/°F.
- A simplification of this data is that for a temperature change of 1°F, a 100 foot length of conduit will expand or contract of 0.015".
- Every bridge crossing installation of **FRE®** Conduit system will require at least one (1) expansion joint per conduit run.

## Thermal Expansion of **FRE**® Conduit – Type AG

AMBIENT TEMP CHANGE (°F)	CONDUIT LENGTH CHANGE (INCHES/100 FT OF CONDUIT)
1°	0.015"
40°	0.600"
80°	1.200"
120°	1.800"
160°	2.400"

The watertight **FRE**® **O-Ring Expansion Joint** is designed to allow 4 inches of travel in either direction, therefore one expansion joint should be installed in every 200 feet to conduit run. An expansion joint will permit up to a 120°F rise or fall in temperature from the temperature at the time of installation, without causing binding or excessive travel within the expansion joint. Further details regarding placement and configuration of expansion joints are detailed in **Section 4** - Work practice for Under bridge Installations.

## FRE® Conduit – Type AG Expansion Fittings

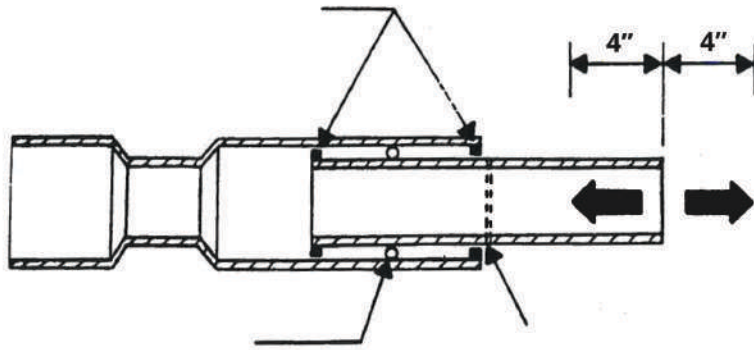

---

O-Ring expansion joints have been specifically designed for use in bridge crossing applications. A silicone O-Ring is used in sealing the unit to keep out dirt and water while maintaining freedom of movement. The unit also employs retaining rings to contain the O-Ring seal and to prevent the sleeve from accidentally disengaging should it be extended too far.

## FRE® Conduit – Type AG Expansion Fittings Location

- Expansion and contraction of the conduit will usually be greater and independent of any expansion and contraction in the bridge structure.
- For this reason, expansion joints and restraining points which anchor the conduit must be employed to adequately control this motion in a predictable manner. An expansion joint must be provided for every **200 feet** of conduit run to adequately control motion.
- To ensure that each expansion joint works independently from the others, the conduit must be securely braced at each **200 foot** interval. The diagram to the right shows a typical bridge installation.

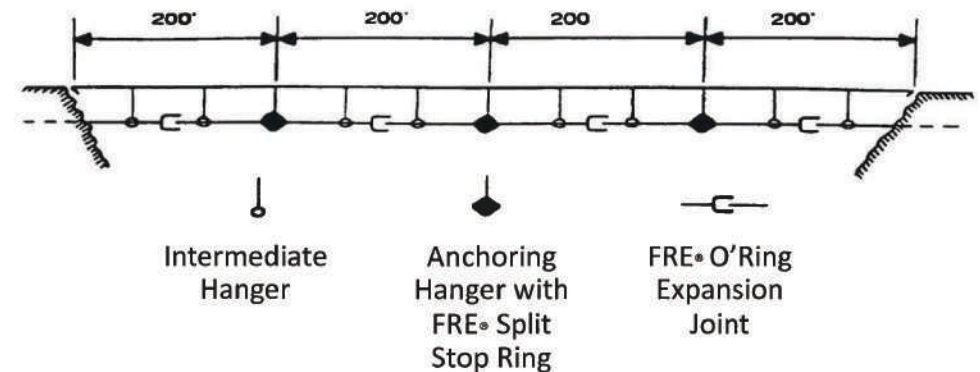

## FRE® Conduit – Type AG Back-to-Back configuration

An alternate method of O-Ring installing expansion joints which merits consideration is the back-to-back technique. With this method, an O-Ring expansion joint is placed on either side of the anchoring hanger as shown in the diagram below.

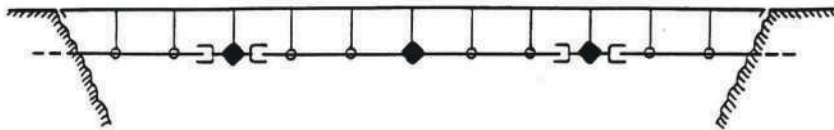

This method may save some installation time when applied to certain bridge types. With this technique, a short length of FRE® Conduit is positioned in the anchoring hanger and held in place by split stop rings on either side of the anchoring hanger. O-Ring Expansion joints are then attached back to back on this short piece of conduit and the conduit run is installed out from these expansion joints in either direction.

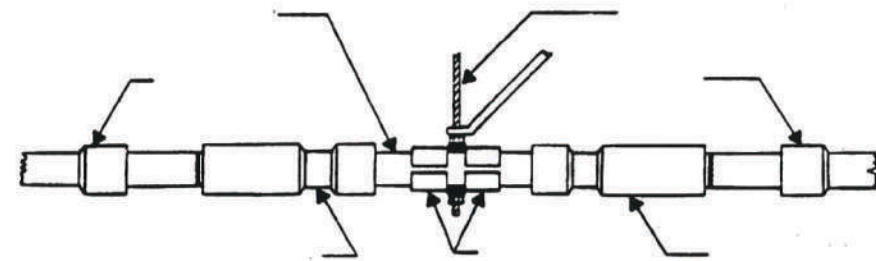

## FRE® Conduit– Type AG Split Stop Rings

The bracing of the conduit every 200' is done with the use of anchoring hangers. These hangers are rigidly fastened to the bridge structure to avoid swaying or bending motion.

The conduit is held firmly in the hanger by use of split stop rings cemented to the conduit on either side of the hanger. The conduit should always be restrained by split stop rings and never by clamping the conduit tightly in the hanger. This procedure restricts the conduit and permits no motion at the anchoring hanger.

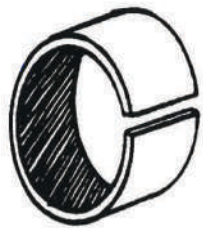

FRE® Split Stop Ring

## FRE® Conduit– Type AG Split Stop Ring Locations

The conduit run between two such anchoring hangers acts as an independent unit until transferring its motion to the expansion joint located in that line.

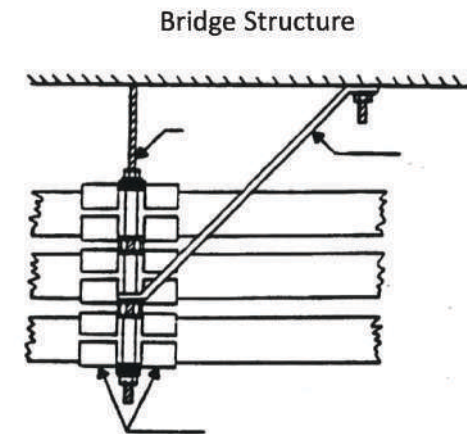



## Hanger Design with **FRE**® Conduit - Type AG

NEC Table 355.30 - RTRC span distance in between supports

Extended Support distance Listing - Reducing # of hangers- lowers installed costs.

FRE Composites' recommends that the following factors be considered in the selection of conduit hangers:

- The hangers - minimum support surface width of 2" - Load bearing capability
- The commercially available grid type of conduit support hanger designed for non-metallic conduits is recommended to minimize abrasion and wear at the duct and hanger interface, the materials should be of the same or similar composition and hardness.
- The hanger opening should be such as to allow free and unrestricted movement of the conduit during installation and during thermal expansion and contraction. The openings should not, however, be so large as to allow the passage of the enlarged conduit bell end, double bell coupling, expansion joints or split stop rings.

Typical grid type  
conduit hanger

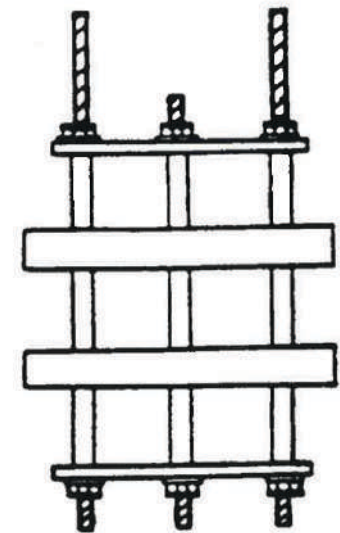

## **FRE® Conduit** – Type AG Bridge vibrations

- Bridge structures are subject to the transmission of vibrations from the road surfaces to the conduit runs.
- Adequate provisions must be made in the use of threaded fasteners and specified fastening torque, lock nuts, lock washers and thread sealants to ensure the hanger's integrity.
- These provisions will reduce costly maintenance and avoid hazardous situations over the life of the installation.

## **FRE® Conduit** – Type AG Joining Methods

The design engineer can either specify a TriSeal™ Push fit joint or two part adhesive to be applied to each spigot.

Factors to be considered in determining the need for adhesive joints versus friction Push fit (TriSeal™) joints are:

- Excessive vibration or movement in the bridge structure may require additional resistance to decoupling.
- Low additional cost for adhesive joints.
- Presence of water flowing through the bridge crossing conduit runs from the existing conduit.

A black and white photograph of the Golden Gate Bridge in San Francisco, viewed from a high angle looking down the length of the bridge towards the city. The bridge's towers and suspension cables are prominent. The city skyline is visible in the background across the water. The sky is dark, suggesting dusk or dawn.

THE EPOXIES

**HazGuard™**

UL 2515A - Supplemental requirements  
Class 1 Div. 2

## HazGuard™ Conduit – Product characteristics

- **Lightweight:** 100 feet of 4" weighs 282 lbs
- **Compressive strength:** Axial 12,000 Psi ASTM D695
- **Tensile strength longitudinal:** 7,000 Psi per ASTM D638
- **Ultimate elongation:** 2% per ASTM D2105
- **Modulus of elasticity in tension:** 1,250,000 per ASTM D2105
- **Modulus of elasticity in bending:** 1,250,000 per ASTM D790
- **Thermal conductivity:** 2.0 BTU / HR / SQ / F° / Inch
- **Coefficient of linear thermal expansion:** 1.37 x 10.5 " / inch / °F
- **Specific gravity:** 1.93 +/- 3
- **Temperature range:** -40°F to 230°F
- **Dielectric strength:** 500 volts / per mil
- **Dissipation factor:** 0.5% average at room temperature per ASTM D348
- **Barcol hardness:** 50 +/- 2 per ASTM D2583
- **Glass content:** 71% +/- 3 per API 15LR
- **Water absorption:** <1% per ASTM D570
- **Flammability:** Article 5.10 (UL 2515)
- **Heat deflection temperature (HDT):** 312°F (156°C) ASTM D648

## HazGuard™ Conduit – Product Applications

Generally destined to Bridge installations-  
Physical damage locations

### Power bridge crossings

- Utilities
- DOT

### Fiber optic

- Large Carriers (AT&T, Verizon and others)
- Empty or Multicell
  - Empty** - installed and small diameter PE pulled
  - Multicell** - Pre-assembled in factory (OMNI - Opticom)

## HazGuard™ Conduit – Listing & Certification

### UL Listing

The National Electrical Code in Article 355 recognizes “Reinforced Thermosetting Resin Conduit (RTRC)” as an acceptable conduit material for Class 1 Division 2 locations - Subjected to Physical damages. “HazGuard™ Conduits” is Listed by Underwriters Laboratories Inc. under file number E53373.

Compliance to NEMA TC14-2515A Standards (Oct. 18<sup>th</sup>, 2002 - Adoption of UL standards)



THE EPOXIES

**FRE<sup>®</sup>** Underwater Conduit system

Own Publication Since 1984

## **FRE®** Underwater conduit – Design & Characteristics

### **Typical installations**

- River and/or crossings
- Power and Fiber

### **Industry Users**

- Southern Nevada Water Authority (SNWA) - Lake Mead crossing
- Hydro-Quebec
- Etc...

Please consult our online catalogue for all product design and characteristics





THE PHENOLICS

---

**BreathSaver®**

Type XW – UL 2515A Supplemental requirements

Type SW - Own Publication since 1993

2-Hour fire Certified



# **XW Breathsaver®**

## **Certification to UL2196 / 2-Hour fire Certified**

### **UL 2196 Certification challenges**

Certification vs. Verified Service Report (VSR) - Underwriter's Laboratories

- Wire fill vs. NEC 40% standard fill rate
- Support distance (Certification vs. UL 2515A Listing)

Acceptance of credentials by Authority Having Jurisdiction (AHJ)

- Liabilities vs. competition

### **Industry Users**

- BART (Bay Area Rapid Transit)
- HART (Honolulu Area Rapid Transit)



## XW Breathsaver® Conduit – Product characteristics

- **Lightweight:** 100 feet of 4" weighs 282 lbs
- **Compressive strength:** Axial 12,000 Psi ASTM D695
- **Tensile strength longitudinal:** 7,000 Psi per ASTM D638
- **Ultimate elongation:** 2% per ASTM D2105
- **Thermal conductivity:** 1.067 Btu.in/ft<sup>2</sup>.h.°F ASTM D335
- **Coefficient of linear thermal expansion:** 1.25 x 10<sup>-5</sup> "/inch / °F
- **Specific gravity:** 1.93 +/- 2
- **Temperature range:** -40°F to 1850°F
- **Dielectric strength:** 500 volts / per mil
- **Dissipation factor:** 0.5% average at room temperature per ASTM D348
- **Barcol hardness:** 50 +/- 2 per ASTM D2583
- **Glass content:** 71% +/-3 per API 15LR
- **Water absorption:** <1.5% per ASTM D570
- **Heat deflection temperature (HDT):** 482°F ASTM D648

## XW Breathsaver® Conduit Listing

### UL Listing

The National Electrical Code in Article 355 recognizes “Reinforced Thermosetting Resin Conduit (RTRC)” as an acceptable conduit material for Class 1 Division 2 locations - Subjected to Physical damages. “Breathsaver Conduits®” is Listed by Underwriters Laboratories Inc. under file number E53373.

Compliance to NEMA TC14-2515A Standards (Oct. 18<sup>th</sup>, 2002 - Adoption of UL standards)

## XW Breathsaver® Certification to UL2196 / 2-Hour fire Certified

### UL 2196 Certification

BreathSaver® Type XW is the only 2-Hour Fire Certified conduit in the United States for both Vertical and Horizontal installations (all type of materials on the market) when installed with Pysmian RHW2 cables (FHIT25C - Certified system)

### Certification vs. Verified Service Report (VSR) - Underwriter's Laboratories

- Pysmian/BreathSaver® Certification  
108 successful tests both vertical and horizontal (3/4" to 6")  
+ 1 VSR - # 10 with Hoffman pull box and two 2 hour splices
- RSCC/Champion Fiberglass - Verified Service Report (VSR)  
2 tests per the requirements of UL 2196

## SW Breathsaver® Conduit – Design & Characteristics

### Typical installations

- Tunnels and Roadways (NFPA502)
- Exposed but concealed locations (Transit installations)

### Industry Users

- MTA (NYC)
- MBTA (Boston)
- WAMATA (Washington DC)
- LA METRO
- SMFTA (San Francisco Municipal Transportation Agency)

Please consult our online catalogue for all product design and characteristics

